

THE KENYA NATIONAL EXAMINATIONS COUNCIL
Kenya Certificate of Secondary Education



Paper 1

121/1

MATHEMATICS Ait. A

Nov. 2025 – 2 ½ hours

Serial No.

1318BB19

Name: **Index Number:**

Candidate's signature: **Date:**

Instructions to candidates:

- (a) Write your name and index number in the spaces provided above.
- (b) Sign and write the date of examination in the spaces provided above.
- (c) This paper consists of **two** sections: **Section I** and **Section II**.
- (d) Answer **all** the questions in **Section I** and only **five** questions from **Section II**.
- (e) **Show all the steps in your calculation, giving your answers at each stage in the spaces provided below each question.**
- (f) Marks may be given for correct working even if the answer is wrong.
- (g) **Non-programmable** silent electronic calculators and KNEC mathematical tables may be used, except where stated otherwise.
- (h) **This paper consists of 18 printed pages.**
- (i) **Candidates should check the question paper to ascertain that all the pages are printed as indicated and that no questions are missing.**
- (j) **Candidates should answer the questions in English.**

For Examiner's Use Only

Section I

1	2	3	4	5	6	7	8	9	10	11	12	13	14	15	16	Total

Section II

17	18	19	20	21	22	23	24	Total

Grand Total

--



SECTION I (50 marks)

Answer **all** the questions in this section in the spaces provided.

1. Without using a mathematical table or calculator, evaluate; (3 marks)

$$\sqrt{\frac{11}{12} - \frac{1}{3} \div 1\frac{1}{2}}$$

2. Baraka earns Ksh 240 per hour working at a supermarket. The employer changed the amount earned per hour in the ratio of 8:7.

Determine the amount that Baraka would earn in $10\frac{1}{2}$ hours at the new rate. (3 marks)

3. Solve for x in the equation.

$$4^{3x} \times 8 = \left(\frac{1}{32}\right)^{2x-3}$$

(3 marks)

4. Solve $-1 \leq \frac{5-2x}{3} < 2x-1$, giving the answer as a combined inequality. (3 marks)

5. The following figure represents a rectangular farm, PQRS, of length 210 m and with 120 m drawn on a grid of 1 cm squares. The dotted area inside the farm represents a flooded section.

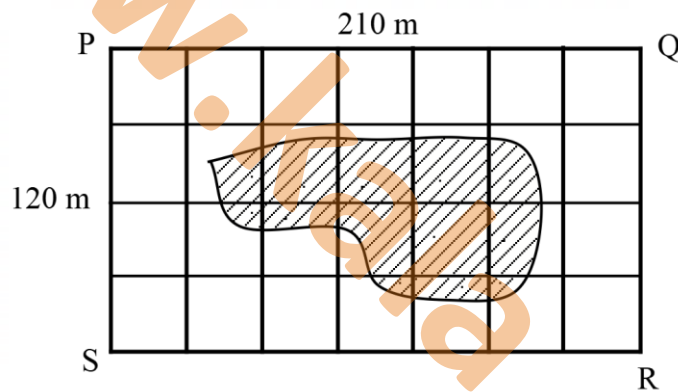

Estimate in m^2 , the area of the farm that is not flooded. (3 marks)

6. A relief organization donated 240 kg of maize and 150 kg of beans to needy families. Each family received exactly the same quantity by mass of either maize or beans. No family received both. Determine the least possible number of the needy families. (3 marks)

7. Simplify $\frac{x^2 - 4y^2}{x^2 + 4xy + 4y^2}$ (3 marks)

8. The area of a sector of a circle is 550 cm^2 . The sector is curved to form an open cone of radius 7 cm. Calculate the height of the cone. (4 marks)

9. A clock which loses 18 seconds every hour was set to read the correct time at 8:00 am on Monday. Determine the time, in 12 hour system, the clock will read on the following Saturday at 11:20 am. (3 marks)

10. In the following figure, line $AB = 5$ cm is a side of a triangle ABC in which $\angle BAC = 120^\circ$ and line $BC = 10$ cm. using a pair of compasses and a ruler, complete triangle ABC and hence measure the size of angle ABC . (3 marks)



11. A shopkeeper bought an item from a wholesaler. If the shopkeeper sells the item for Ksh 2 740, he would make a profit of Ksh $3x$. If the shopkeeper sells that item for Ksh 2 340, he would make a loss of Ksh $2x$. Determine the amount that the shopkeeper paid for the item.

12. The following table shows the frequency distribution of marks scored by students in a Mathematics test. The frequencies for the two classes are not shown. The table also shows the height of each rectangular bar of a histogram drawn to represent the information on the scored by students.

Marks	10 – 11	15 – 19	20 – 29
Frequency	7		
Height of bar	1.4	2	1.5

Calculate the missing frequencies.

(3 marks)

13. On the following grid, line $A'C'$ is part of $\Delta A'B'C'$. Triangle $A'B'C'$ is the image of ΔABC after a reflection along a mirror line.

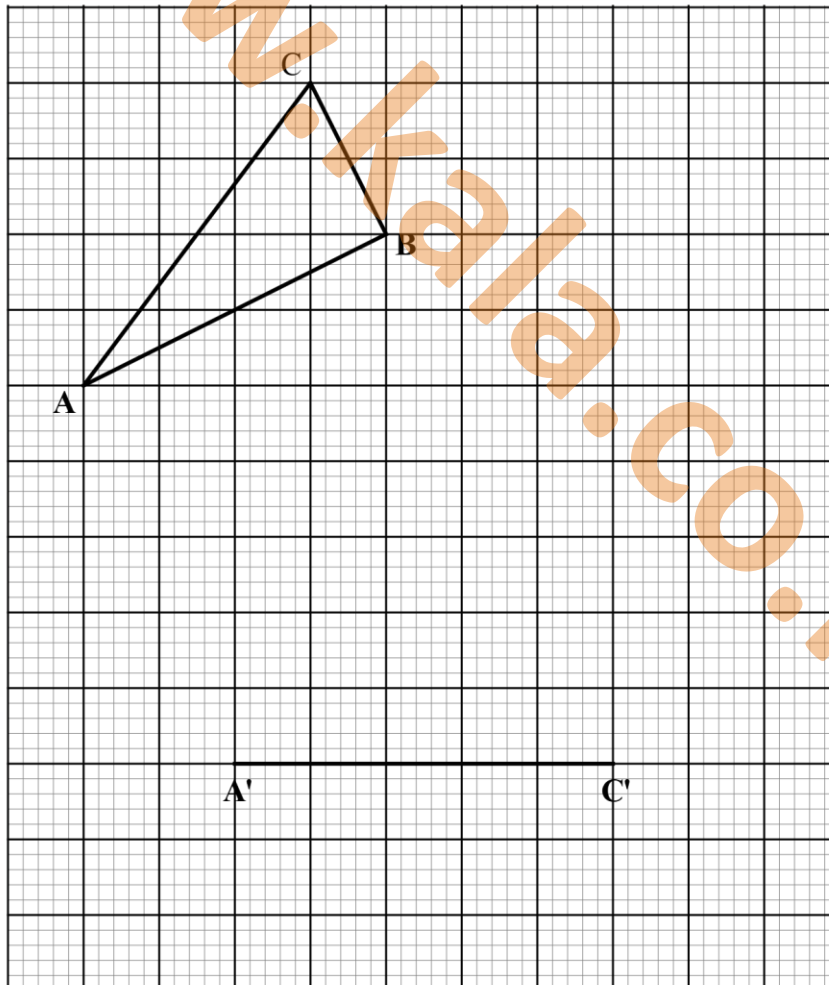

On the same grid, draw the mirror line and hence complete $\Delta A'B'C'$.

(3 marks)

Kenya Certificate of Secondary Education, 2025

14. The figure below represents a prism ABCDEFGH. The cross section of the prism is a trapezium. $BC = CF = 5\text{ cm}$ $AD = HE = 2\text{ cm}$ and $AB = DC = 2.5\text{ cm}$.

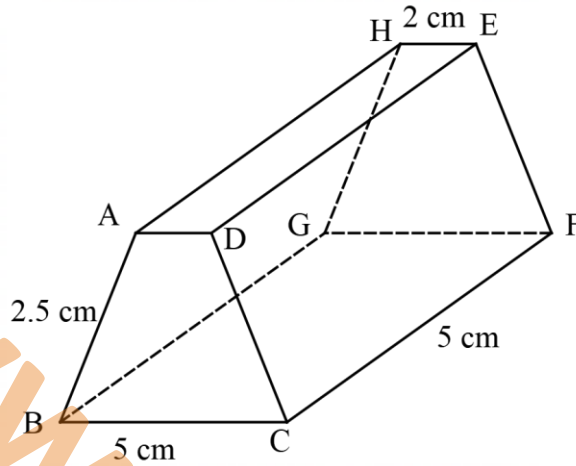

Draw a labelled net of the prism.

(3 marks)

15. In the following figure, triangle ABC is right angled at B and $AB = 8$ cm. D is a point on AC such that $AD = 5$ cm and the area of triangle ABD = 10 cm².

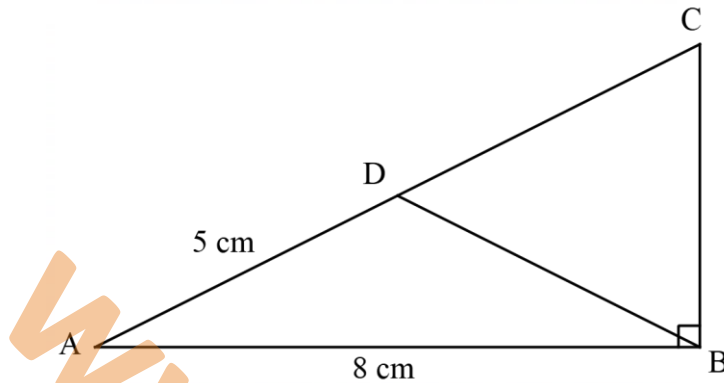

Calculate the length of side BC.

(4 marks)

16. The quadratic curve $y = 3x^2 - 4x$ passes through the point $P(1, -1)$. Determine the equation of a tangent to the curve at point P leaving the answer in the form $ax + by = c$, where a , b and c are scalars. (3 marks)

SECTION II (50 marks)

Answer only **five** questions in this section in the spaces provided.

17. The road connecting town A to town B is 160 km long. A lorry, travelling at an average speed of 45 km/h, left town A for town B at 11.50 am. At that same time, a car travelling at an average speed of 75 km/h, left town B for town A. The two vehicles met at C, a town along the same road.

(a) Determine:

(i) the time when the two vehicles met. (4 marks)

(ii) the distance, in km, from town A to town C. (2 marks)

(b) The car stopped at town C for a period of 1 hour 40 minutes. The lorry continued with its journey at the same speed of 45 km/h. After the stop, the car left town C for town A and arrived at its destination at the same time as the lorry arrived at B.

Determine the average speed of the car for the journey from town C to town A.

(4 marks)

18. Figure VABCDEFGH shows a solid consisting of a right pyramid mounted on a rectangular block. The right pyramid and the rectangular block have an identical square base of length 6 cm. The height of the rectangular block is 10 cm while $VA = VB = VC = VD = 5$ cm.

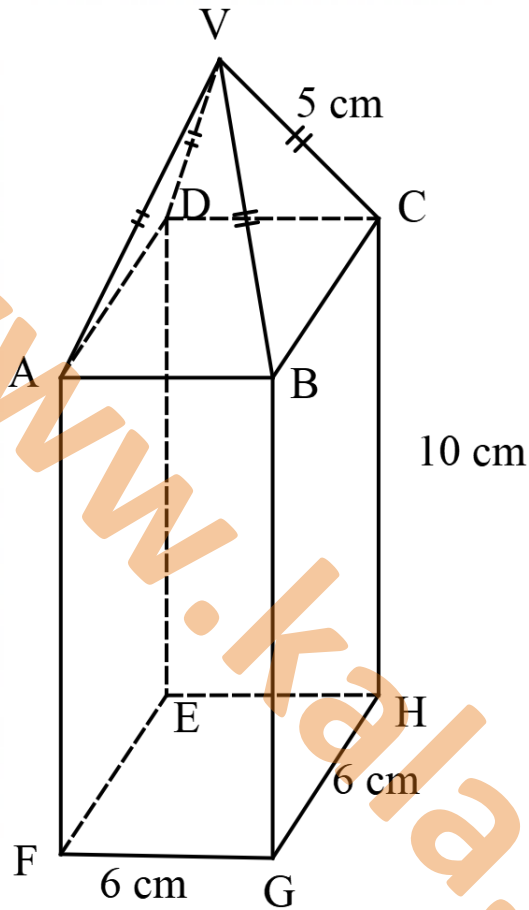

(a) Calculate the volume of the solid.

(4 marks)

- (b) The solid is cut into two identical halves along the plane of symmetry VAFHCV. Calculate the surface area of one of the pieces. (6 marks)

www.kala.co.ke

19. Two lines, L_1 and L_2 are parallel. Line L_3 is perpendicular to both lines L_1 and L_2 .

- (a) (i) Line L_1 passes through points $A(-3, 6)$ and $B(3, 9)$. Find the gradient of line L_1 .
(2 marks)

- (ii) Line L_2 intersects the x -axis at point $C(-5, 0)$. Determine the equation of L_2 in the form $y = mx + c$.
(2 marks)

(b) Line L_3 intersects lines L_1 and L_2 at points $A(-3, 6)$ and P respectively.

- (i) Determine the equation of L_3 in the form $y = mx + c$. (3 marks)

- (ii) Determine the coordinates of point P . (3 marks)

20. A transporter was contracted to transport 133 tonnes of sand from site A to site B. The transporter used two lorries; a 7-tonne lorry and a 14-tonne lorry. The transporter incurred a cost of Ksh 3 000 per trip for the 7-tonne lorry and Ksh 4 000 per trip for the 14-tonne lorry. The total cost incurred by the transporter was Ksh 47 000.

(a) Given that the 7-tonne lorry made x trips while the 14-tonne lorry, made y trips, write down two equations to represent the information. (2 marks)

(b) Use matrix method to solve the equation in (a). (5 marks)

(c) The transporter was paid Ksh 500 per tonne of sand delivered to site B. calculate the amount of profit made by the transporter. (3 marks)

21. In the grid provided, the coordinates of points P and Q are (3, 3) and (8, 5) respectively. Vector \mathbf{PQ} is also shown.

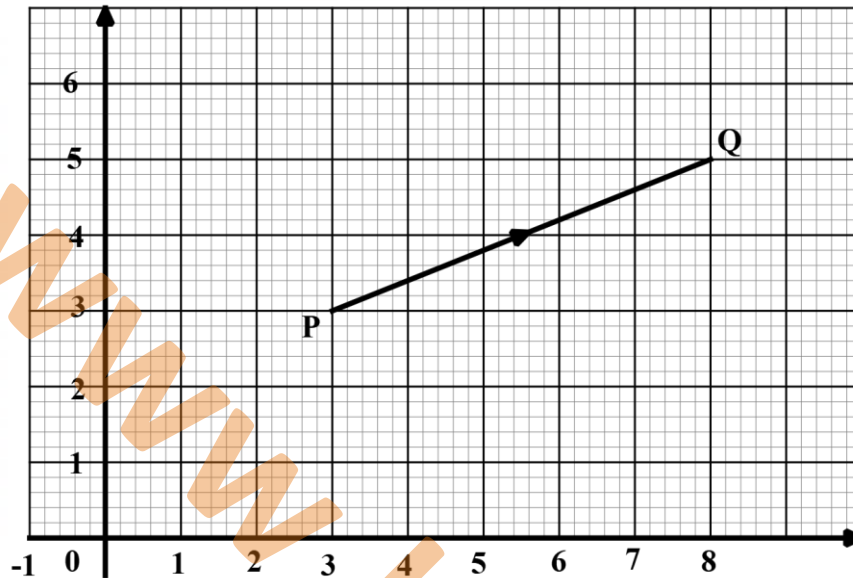

- (a) Express \mathbf{PQ} as a column vector. (2 marks)

- (b) Two vectors, $\mathbf{a} = \begin{pmatrix} 3 \\ -1 \end{pmatrix}$ and $\mathbf{b} = \begin{pmatrix} -1 \\ 4 \end{pmatrix}$ are such that $k\mathbf{a} + h\mathbf{b} = \mathbf{PQ}$ where k and h are scalars.

- (i) Determine the values of k and h . (4 marks)

- (ii) On the same grid, from point P, represent by accurate drawing, the sum of vectors ka and hb . (2 marks)

- (c) Determine the magnitude of vector ka . (2 marks)

22. In the following figure, lines $AB = 10$ cm and $AD = 5$ cm are part of a trapezium ABCD in which line AB is parallel to line DC. Angle $DAB = 65^\circ$.

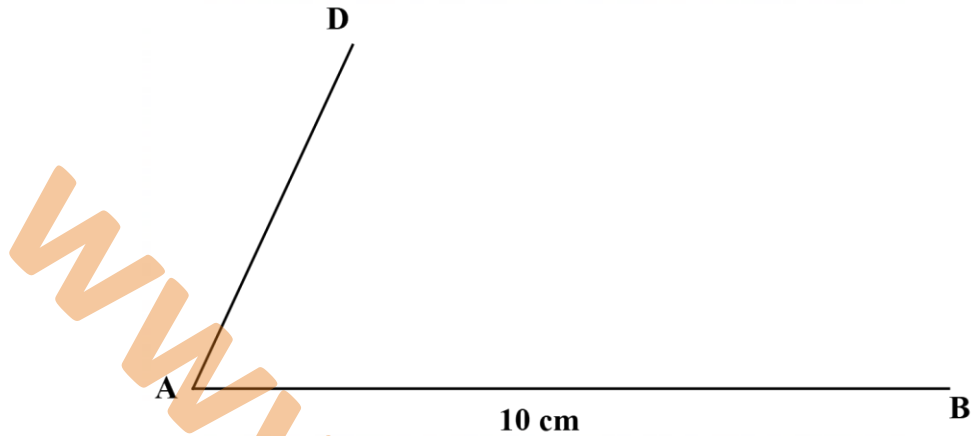

- (a) On the same figure, using a ruler and a pair of compasses only;
- (i) complete trapezium ABCD given that $\angle ABC = 67.5^\circ$. Measure the length of line DC; (4 marks)
 - (ii) drop a perpendicular line from D to meet AB at E. Measure the length of line DE; (2 marks)
 - (iii) draw an arc of a circle, center A and radius 5 cm. The clockwise directed arc should join D to a point F on line AB. (1 marks)
- (b) Calculate the area of trapezium ABCD that lies outside the arc drawn in (a)(iii). (Take $\pi = 3.142$) (3 marks)

23. The quantity of petrol in litres used by 40 boda boda riders on a particular day is as follows.

1.7	2.9	2.1	2.8	3.6	2.1	1.6	2.8
4.0	2.4	3.1	1.8	2.5	1.9	2.6	3.2
3.1	1.5	3.4	2.9	2.9	3.4	2.1	2.6
3.4	4.1	3.9	4.3	3.7	2.8	2.3	2.7
3.3	2.7	2.4	3.5	2.0	1.5	1.8	2.3

The cost of 1 litre of petrol is Ksh 160.

(a) Starting with 1.5 litres and using a class size of 0.5, draw a frequency distribution table for the data. (2 marks)

(b) Use the frequency distribution table in (a) to estimate:

(i) the mean amount of money spent on petrol by the boda boda riders on that day. (4 marks)

(ii) the median amount of money spent on fuel by the median boda boda rider. (4 marks)

24. The figure ABCDEF represents a plot of land. Length $AB = 50$ m, $BC = y$ m, $CD = x$ m and $DE = 40$ m. The figure also shows an adjacent plot of land BCDG. All the angles in figure are right angles.

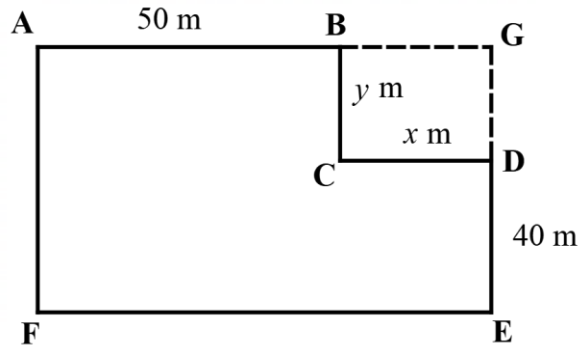

The owner of plot ABCDEF later purchased plot BCDG. Given that the perimeter of plot BCDG is 60 m:

- (a) (i) Write an expression for y in terms of x . (2 marks)

- (ii) Write down a simplified expression in x for the area of the entire plot of land AGEF. (3 marks)

- (b) (i) Determine the dimensions of plot BGDC that would maximize the size of the entire plot of land AGEF. (3 marks)

- (ii) Determine, in m^2 , the maximum possible area of plot AGEF. (2 marks)

THIS IS THE LAST PRINTED PAGE

Kenya Certificate of Secondary Education, 2025